

Top interchangeable kit WSO Keysight/i1000D

Item 53910



GO TO PRODUCT

ingun[®]

Partner for Future Technology

- Trusted interchangeable kits for Keysight inline test systems
- Precise, reliable contacting with peRFectly configured guides
- Modular design with bottom interchangeable kit (WSU) and top interchangeable kit (WSO)
- Robust, durable design with outstanding service life

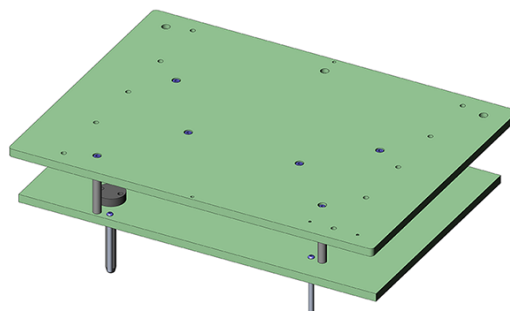

General data

Product group:	Inline interchangeable kit (WS)
Subseries:	Keysight i1000D
Series:	WS Keysight
Version:	With interface
Scope of delivery:	Unassembled
Dual-stage contacting:	Yes
Double-sided contact:	Yes
Min. temperature:	10 °C [50 °F]
Max. temperature:	60 °C [140 °F]

Technical data

Test probe installation height, top:	16 mm [.629 in]
Test probe installation height, bottom:	13 mm [.511 in]
Test probe installation height, dual-stage, top:	16 mm [.629 in]
Test probe installation height, dual-stage, bottom:	18.3 mm [.72 in]
Free space above PCB:	58 mm [2.28 in]
Useable area (WxD):	390 x 280 mm [15.3 x 11 in]
Outer dimensionS (WxDxH):	459 x 340 x 167 mm [18 x 13.3 x 6.57 in]

INGUN Prüfmittelbau GmbH

Max-Stromeyer-Straße 162
78467, Constance, Germany
Phone +49 7531 8105-0
Customer hotline +49 7531 8105-888
Fax +49 7531 8105-65
info@ingun.com



Prices and delivery times on request.
Technical changes reserved. 04/26_GB

Learn more about
Inline interchangeable kit



INLINE INTERCHANGEABLE KITS

ingun.com