



- Equipped with INGUN test probes
- Suitable for test fixtures with internal or external Pylon interface
- Consistently low contact resistances and replicable measured values
- High contact reliability and transmission quality
- Reliable transmission of radio-frequency signals within the scope of the specification

### Application

Interface blocks (SB) are used to reliably transmit signals between test device and test system in internal and external Pylon interfaces. Radio-frequency blocks are suitable for the reliable transmission of frequencies within the scope of their specification.

### Signal transmission

The signal is transmitted via two opposing interface blocks, which are designed for a working distance of  $15.1 \pm 0.5$  mm between their mounting surfaces.

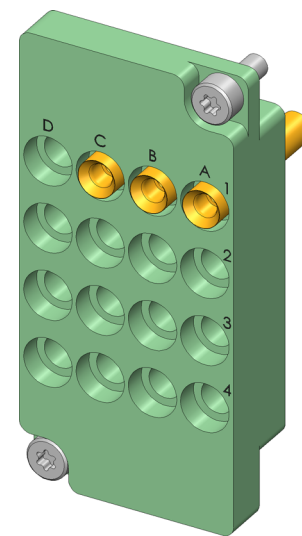

### Delivery

The product is delivered partially assembled in the specified position, including assembly material.

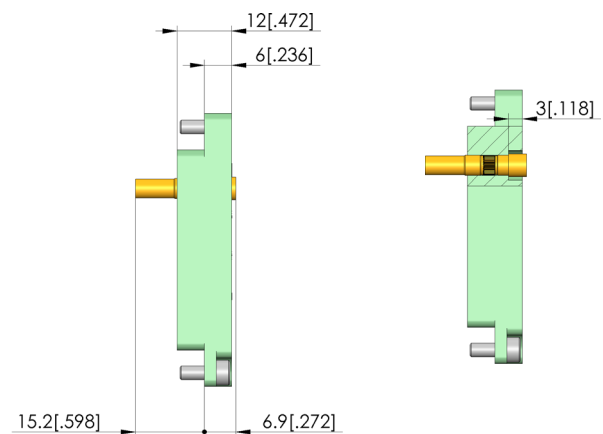
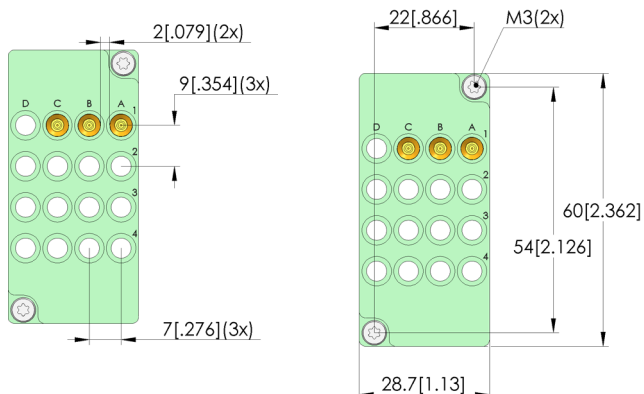

### General data

Product group:	Interface blocks (SB)
Series:	SB-HF
Type:	Radio-frequency block
Version:	Device under test (DUT) side
Accessory type:	Customising accessories
Component assembly:	SB-810-Z (MCX)
Weight:	0.029 kg [.063 lbs]
Min. temperature:	-30 °C [-22 °F]
Max. temperature:	80 °C [176 °F]
RoHS-compliant:	Yes

### Electrical data

Impedance:	50 Ohm
------------	--------

### Compatible with

Compatible mating part 1:	SB-T-HF-016-0,7GHz-03
MA exchangeable kits (ATS MA):	ATS MAxx

### Technical data

Working distance:	15,1 +/- 0,5 mm
Connection:	SE-RG316-0011
Number of poles:	3 (fixed positions)
Frequency up to:	.7 GHz

### INGUN Prüfmittelbau GmbH

Max-Stromeyer-Straße 162  
78467, Constance, Germany  
Phone +49 7531 8105-0  
Customer hotline +49 7531 8105-888  
Fax +49 7531 8105-65  
info@ingun.com

