

High-current multi-heads

HCM-667-0001 C01-08000-03

Item HCM-667-0006



GO TO PRODUCT

ingun[®]

Partner for Future Technology

Scaling of current carrying capacity using high-current multi-head solutions

Contacting of battery cells with higher capacities

- Reliable contact of battery cells
- Modular design enables scalability of current transmission using well-established INGUN products
- Increase in maximum current transmission thanks to cooling feature
- Optional cooling of contact surface using GKS-667
- Voltage monitoring via a central sense contact probe possible
- TKS-667 integrated in the center for temperature and voltage measurement
- Easy installation in plate or busbar via the threaded connection

Application

HCM-Series is specially developed for the flexible scalability of high-current contacting. The modular design makes it possible to adapt the product characteristics to the application, and therefore always provide the right product for a high variable range of DUTs, as is the case with the contacting of battery cells.

Construction

HCM-Products each consist of a base body and several high-current test probes which create a parallel circuit. The functionality can be additionally extended using a centrally positioned sense contact probe or temperature measurement probe with integrated sense tap. Optional air-cooling probes, as an alternative to the current-transmitting test probes, are also available.

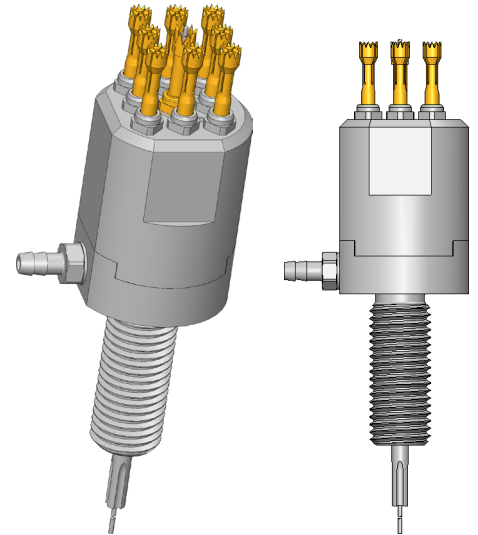

1:1

Installation

HCM Products can be installed in a corresponding hole on a probe plate using lock nuts or installed directly in a busbar via a corresponding threaded hole. If a HCM-Product is installed in a non-conductive plate, for example, the current connection can be made at the threaded bolt via a cable lug. The optional sense contact probe, to be connected to the soldering recess provided, and the temperature sensor are dissipated centrally.

Note:

The base bodies are designed for either five or eight current-transmitting test probes from the BCP-120, BCP-113 and BCP-667 series with various tip styles, which can be freely configured in terms of both quantity and layout. By combining the modular high-current multi-head solution with BCP-667 probes, which were specifically developed for contacting battery cells with oxidised contact surfaces, it is possible to greatly reduce the power losses that occur during cell production.

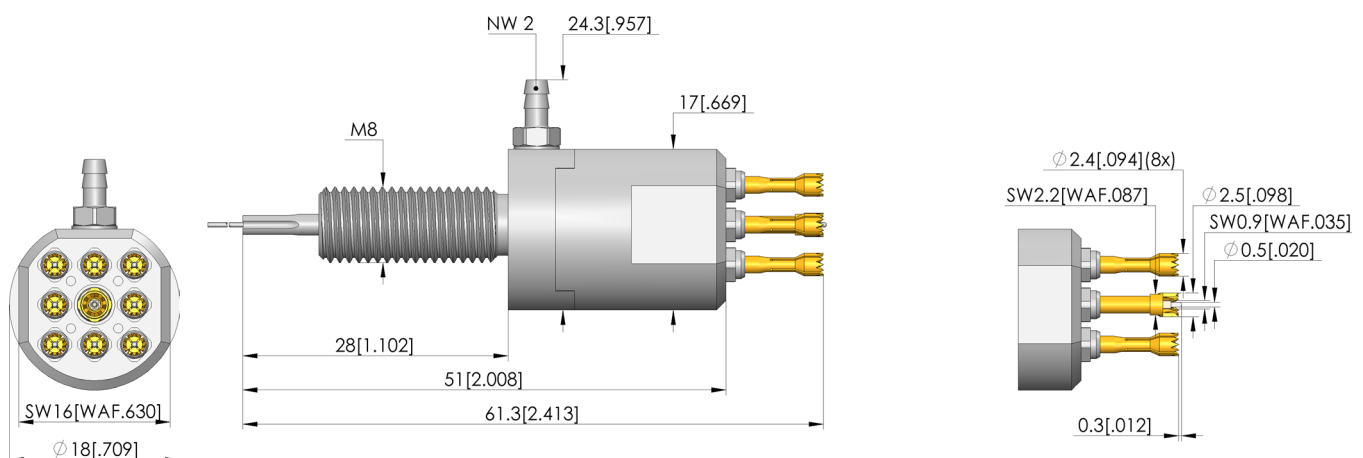

Sense line including temperatur sensor
TKS-667 388 250 A 5602 M-T5



High-current multi-heads

HCM-667-0001 C01-08000-03

Item HCM-667-0006



GO TO PRODUCT

ingun[®]

Partner for Future Technology

General data

Screw-in torque max.:	100 cNm [8.85 lbf-in]
Product group:	Standard HSS (screw-in)
Sub-product group:	Standard HSS (screw-in)
Series:	HCM-667
Application rec.:	
Grid:	19 mm [748 mil]
Contacting from:	-
Magnetic:	Yes
Installation type:	Screw-in
Quick-exchange system:	No
Type of test probe connection:	Thread connection
Adjustable installation height:	No
Non-rotating:	Yes
Screw-in torque:	100 cNm [8.85 lbf-in]
Min. temperature:	-40 °C [-40 °F]
Max. temperature:	80 °C [176 °F]
RoHS-compliant:	Yes

Tip style data

Tip style:	68 expanding tip with front-facing points/cutting edges
Tip diameter:	2.4 mm [.094 in]
Tip style surface:	A gold
Tip style material:	3 CuBe

Electrical data

Current load capacity / rated current:	400 A
Rated current on copper @ $\Delta T \leq 20$ K:	150 A
Rated current on copper @ $\Delta T \leq 60$ K:	400 A
Rated current on aluminium @ $\Delta T \leq 20$ K:	120 A
Rated current on aluminium @ $\Delta T \leq 60$ K:	200 A
Typical resistance (Ri), connection on plunger:	1 mOhm

Mechanical data

Total length:	61.3 mm [2.41 in]
Barrel diameter:	18 mm [.708 in]
Maximum stroke:	5.3 mm [.208 in]
Spring pre-load:	13.69 N [49.2 ozf]
Spring force at working stroke:	45.6 N [164 ozf]
Recommended working stroke:	4 mm [.157 in]

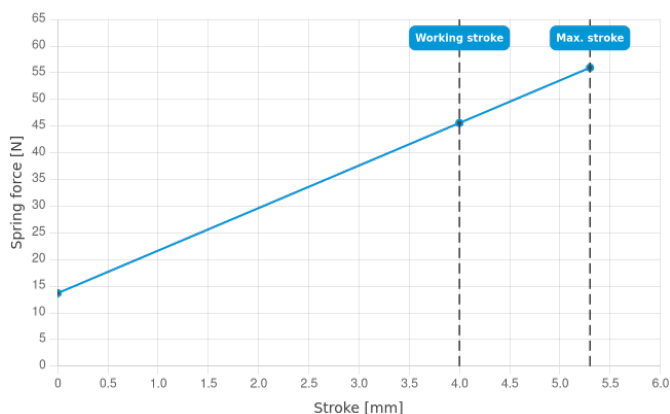

INGUN Prüfmittelbau GmbH

Max-Stromeyer-Straße 162
78467, Constance, Germany
Phone +49 7531 8105-0
Customer hotline +49 7531 8105-888
Fax +49 7531 8105-65
info@ingun.com



Prices and delivery times on request.
Technical changes reserved. 06/26_GB

Learn more about
High-current test probes



HIGH-CURRENT TEST PROBES

ingun.com