

This technical documentation is intellectual property of INGUN Prüfmittelbau GmbH. Unless otherwise contractually agreed in writing, it is not permitted to duplicate or disseminate it, nor may it be made accessible to third parties in any other way, or otherwise be misused without our explicit prior consent.

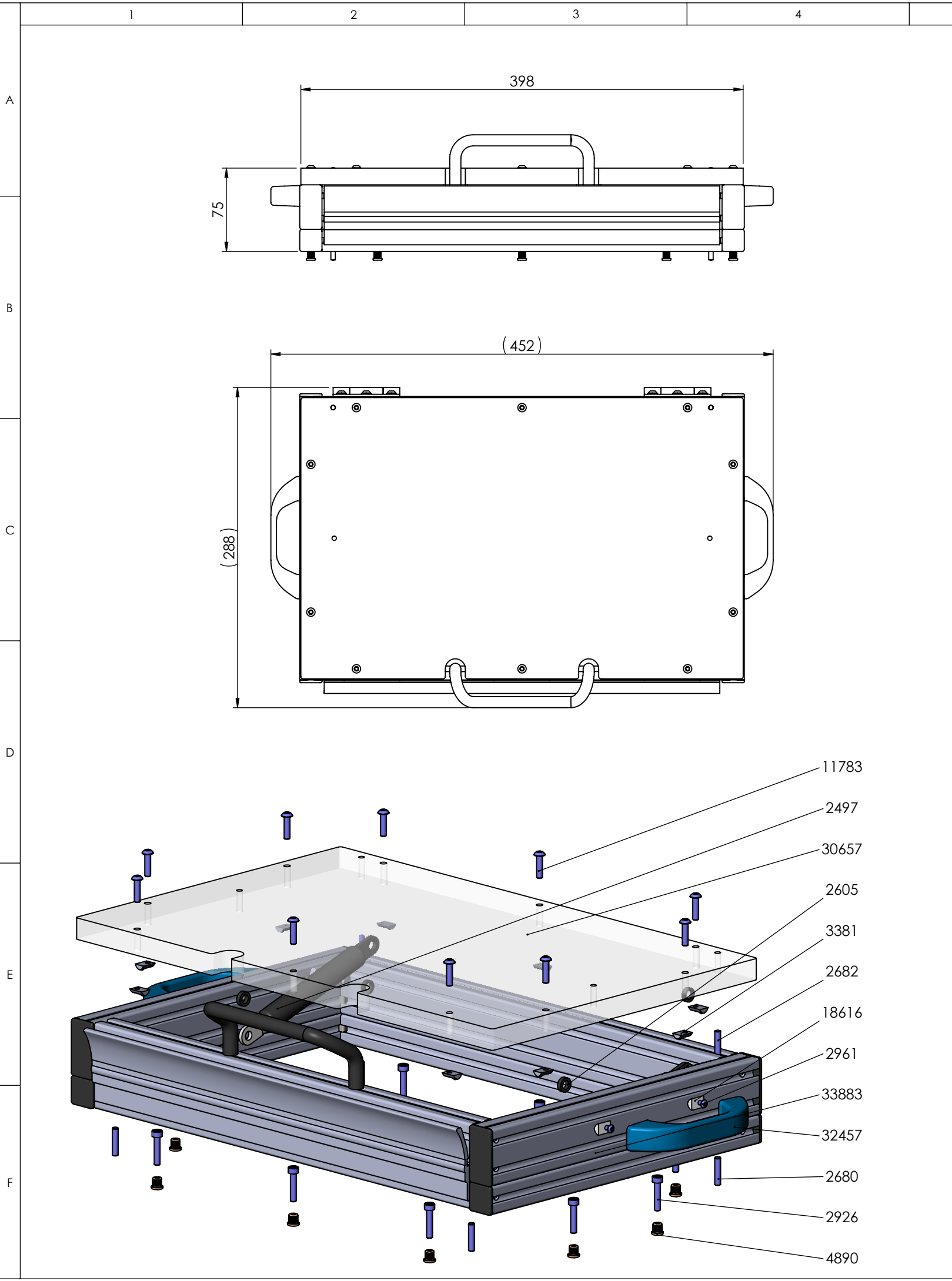

Art.-Nr.: Part no.:	Menge: Amount:	Benennung DE: Description DE:	Benennung EN: Description EN:
33883	1	NHR-400-255-VL	NHR-400-255-VL Pressure frame
30657	1	NHP NDH-400-255-VL-ESD	NHP NDH-400-255-VL-ESD Pressure frame plate
3381	10	Nutenstein 5 M4	Sliding block 5 ITEM M4
2497	2	GDF-185-60-050N-A6-A6	GDF-185-60-050N-A6-A6 Gas pressure spring
18616	4	Nutenstein 5 St M3	sliding block 5 ITEM M3
32457	2	Griff in RAL 5015 blau	Handle, blue
2605	4	Abstandsrolle 6,2 x 3	Distance roll 6,2 x 3 Lutz Nr.168.09.03
11783	10	Linsenschraube M 4x 16 T20	Button head screw M 4x 16 T20 ISO 7380 - A2
2961	4	Linsenschraube M 3x 8 T10	Button head screw M 3x 8 T10 ISO 7380 - A2
2682	2	Zyl.-Stift D 4m6x 30	Parallel pin D 4m6x 30 ISO 8734 C1 - A2
2680	4	Zyl.-Stift D 4m6x 20	Parallel pin D 4m6x 20 ISO 8734 C1 - A2
2926	10	Zyl.-Schraube M 4x 20 T20	Head cap screw M 4x 20 T20 ISO 14579 - A2
4890	10	GB-M04-07,5mm-G	GB-M04-07,5mm-G Bushing

RoHS-2

Maßstab/Scale: 1:4	Benennung/Designation: NDH-400-255-VL-ESD Niederhalter <i>NDH-400-255-VL-ESD Pressure frame unit</i>	Index: 1	Blatt/Sheet 1 von 2 DIN A3
gespeichert/saved: 30.09.2024 09:00:23	Artikel-Nr./PartNo.: 33884		
Montageanleitung/instruction sheet			

This technical documentation is intellectual property of INGUN Prüfmittelbau GmbH. Unless otherwise contractually agreed in writing, it is not permitted to duplicate or disseminate it, nor may it be made accessible to third parties in any other way, or otherwise be misused without our explicit prior consent.
 Diese technische Unterlage ist geistiges Eigentum der Fa. INGUN Prüfmittelbau GmbH. Sofern keine anderslautende schriftliche vertragliche Regelung besteht, darf sie ohne ausdrückliche vorherige Einwilligung weder vervielfältigt, noch verbreitet, noch Dritten in sonstiger Weise zugänglich gemacht werden, noch anderweitig missbraucht werden.

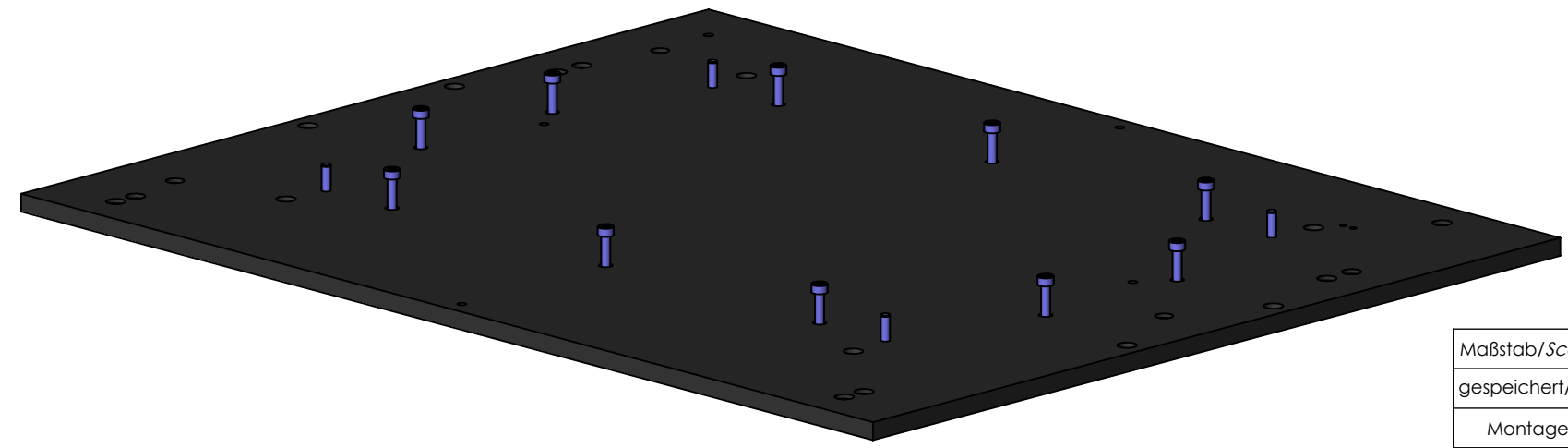
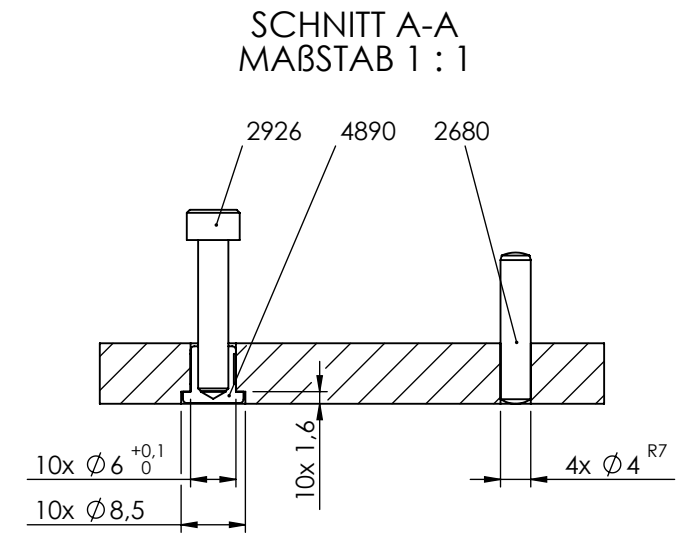
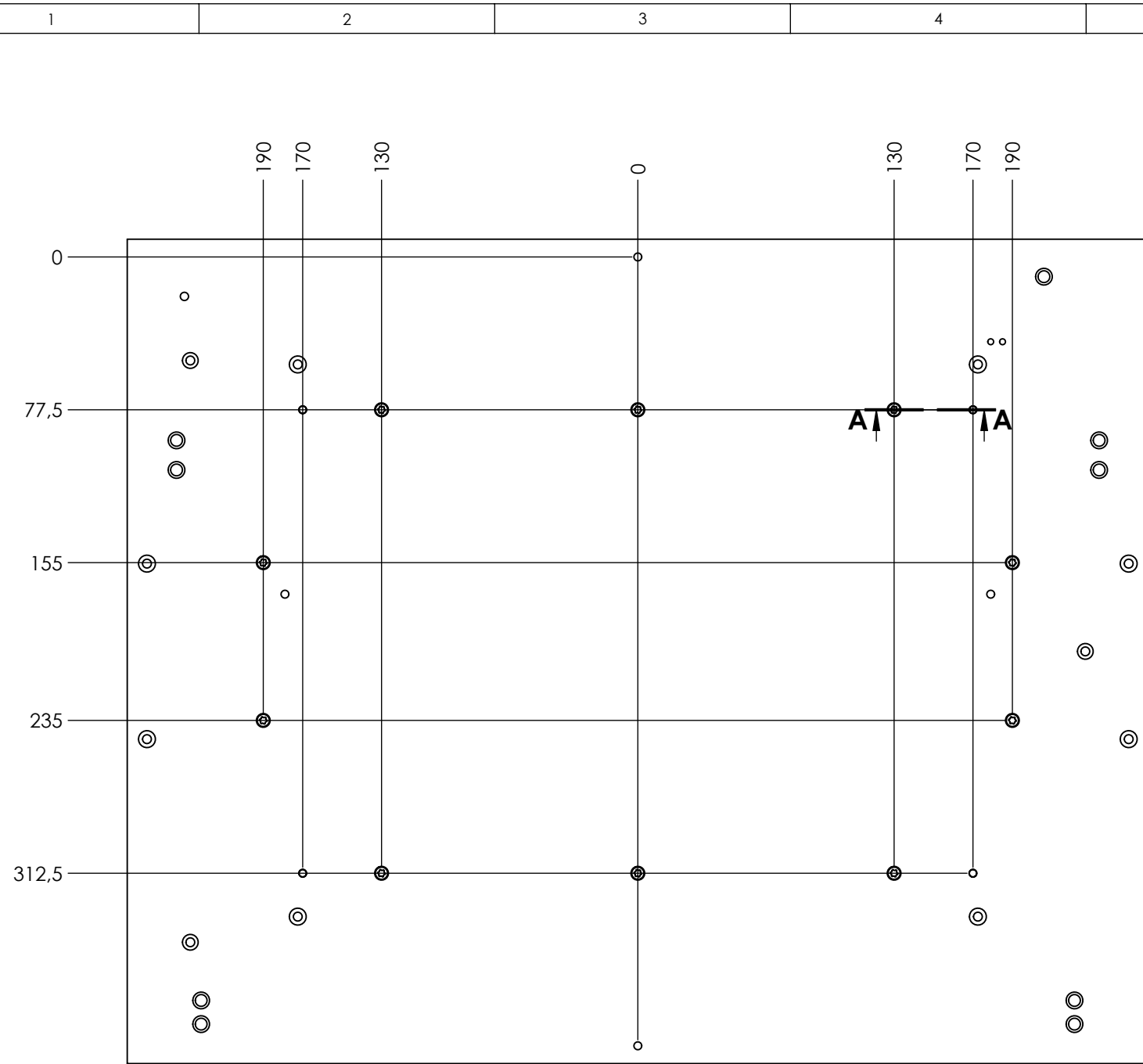

Maßstab/Scale: 1:3	Benennung/Designation: NDH-400-255-VL-ESD Niederhalter NDH-400-255-VL-ESD Pressure frame unit	Index: 1	Blatt/Sheet 2 von 2 DIN A3
gespeichert/saved: 30.09.2024 09:00:23	Artikel-Nr./PartNo.: 33884		
Montageanleitung/instruction sheet			

RoHS-2