



直接访问产品

- 电缆适配器,用于测试连接器 113658 - PS-HSAL2-M-012-G5-B-01
- 如要将自备的电缆焊接到测试系统,应使用 AWG25 及以上的绞合线。
- 屏蔽式外壳
- 可固定的电缆应力消除装置

功能和安装:

When soldering the contact element with an individual cable, 12-pole, AWG 25, or higher, solder in the slot of the pins to ensure the solder joint does not protrude beyond the outer diameter of the contact element. Press the contact elements in fully using the SW-ZW-GKS-075 insertion tool. Observe the specific pin configuration (1-12). Then screw the housing onto the test plug using 2x M1.6 screws and tighten the cable strain relief if required.

INGUN SELECTION

NEW

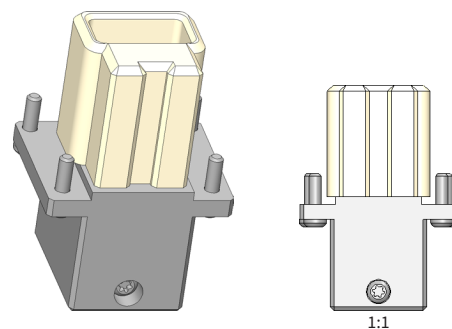

1:1

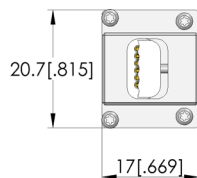
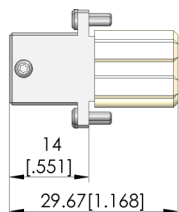
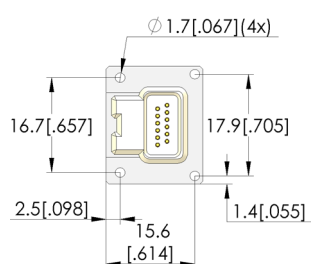

M1.6x6 T5 (5x)

一般数据

产品组:
结构系列:
子系列:
最小温度:
最大温度:
RoHS 符合性:

插头 (SE)
SE-HSAL
SE-HSAL 连接器
0 °C
50 °C
是

插头数据

接口 1:
公母性 1:
规格 1:

HSAutolink2
F 信号线母头/插座/ Female/Jack
直

PS-HSAL2-M-012-G5-B-01

SE-HSAL2-12-M-G-000

产品 114617



直接訪問產品

ingun®

Partner for Future Technology

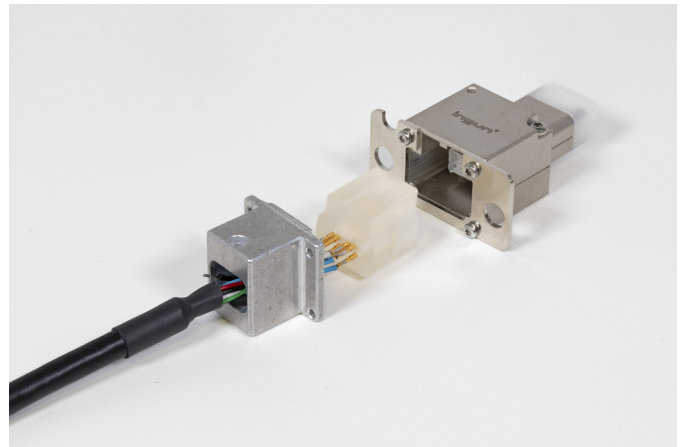
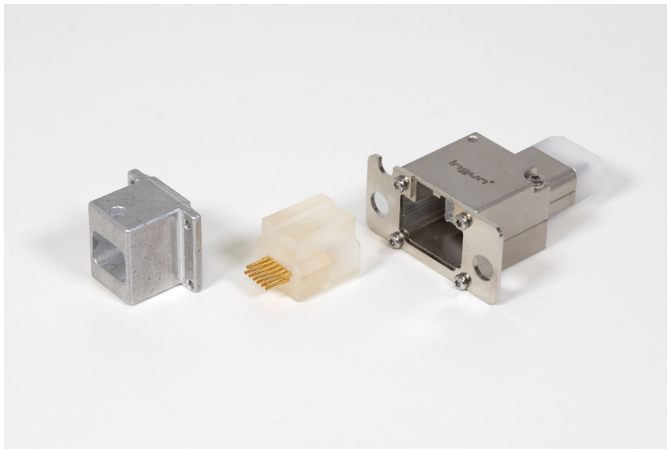
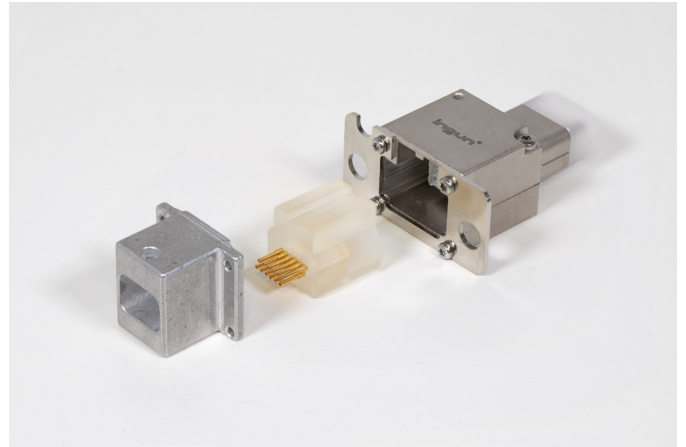
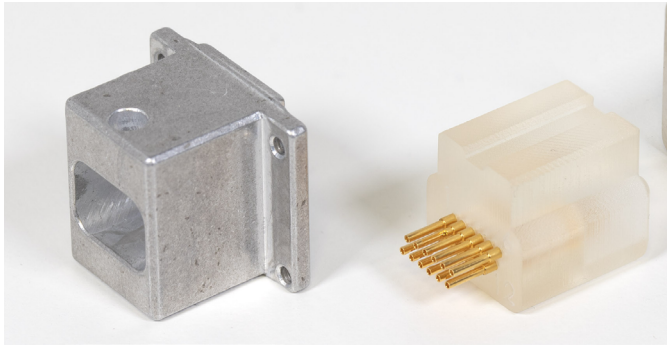

INGUN Prüfmittelbau GmbH

Max-Stromeyer-Straße 162
78467 Konstanz, 德国
中央办公室.+49 7531 8105-0
客户热线.+49 7531 8105-888
传真 +49 7531 8105-65
info@ingun.com



根據要求提供價格和交貨時間。
保留技術更改。04/26_CN

关于该主题的更多信息
探针

