

This technical documentation is intellectual property of INGUN Prüfmittelbau GmbH. Unless otherwise contractually agreed in writing, it is not permitted to duplicate or disseminate it, nor may it be made accessible to third parties in any other way, or otherwise be misused without our explicit prior consent.

1	2	3	4	5	6	7	8
Pos.-Nr.: Item-no.:	Menge: amount:	Benennung DE: description DE:	Benennung EN: description EN:				
1	2	Kulissenstein für MA	slide block for MA drive unit				
2	4	Zylinderstift mit Anschlagfase	cylindrical pin with chamfer 6x16				
3	12	Gleitlager	slide bearing igus JFM 0608-04				
4	2	Miniaturlager d6 15-b5	bearing Misumi B696ZZ				
5	2	Gleitlager iglidur zylindrisch	slide bearing				
6	2	Scheibe mit Fase D 6,4	washer D 6,4 DIN 125A - A2				
7	2	Scheibe 3xd 4.3x12x1	washer				
8	2	Koppel MA 2113/2114	side coupler MA 2113/2114 drive unit				
9	2	Koppelrolle gelagert	friction bearing				
10	4	Zylinderstift mit Anschlagfase	cylindrical pin 6/4 x 16mm				

Montagehinweis:

- B1 demontieren
- A1 lösen
- ATE öffnen
- C1 entnehmen

Instruction for assembly:

- remove B1
- loosen A1
- open up drive unit
- remove C1

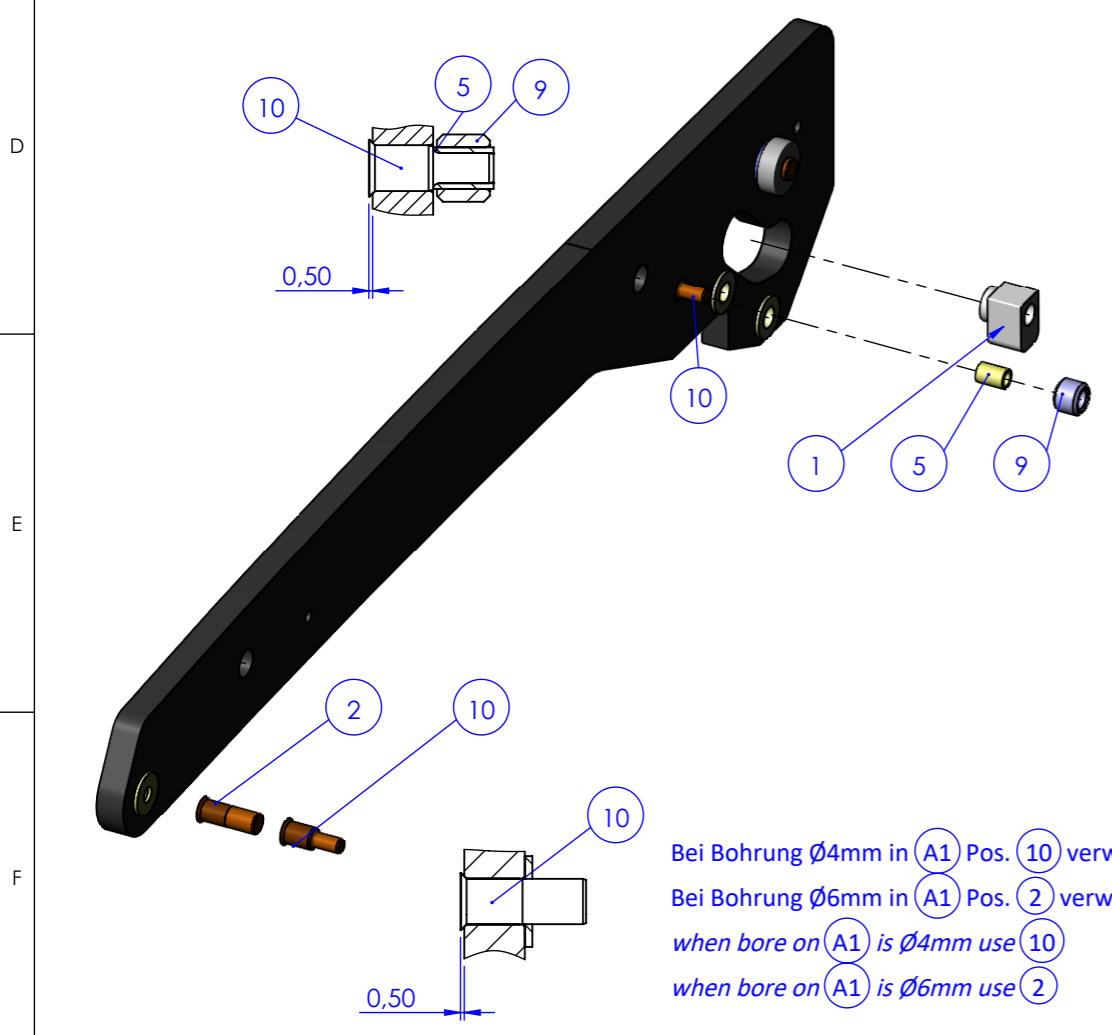
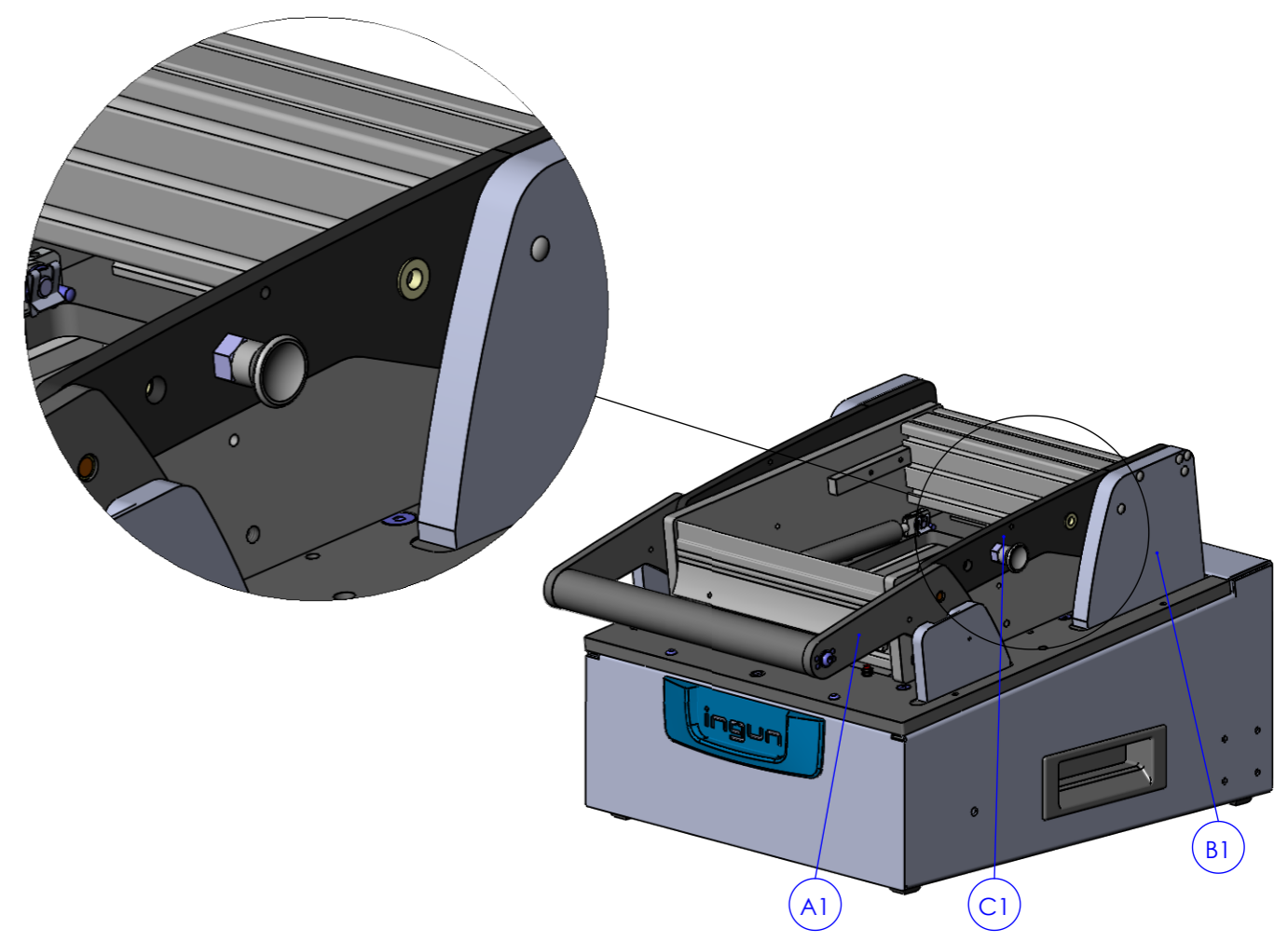

Bei Bohrung $\varnothing 4\text{mm}$ in A1 Pos. 10 verwenden
 Bei Bohrung $\varnothing 6\text{mm}$ in A1 Pos. 2 verwenden
 when bore on A1 is $\varnothing 4\text{mm}$ use 10
 when bore on A1 is $\varnothing 6\text{mm}$ use 2

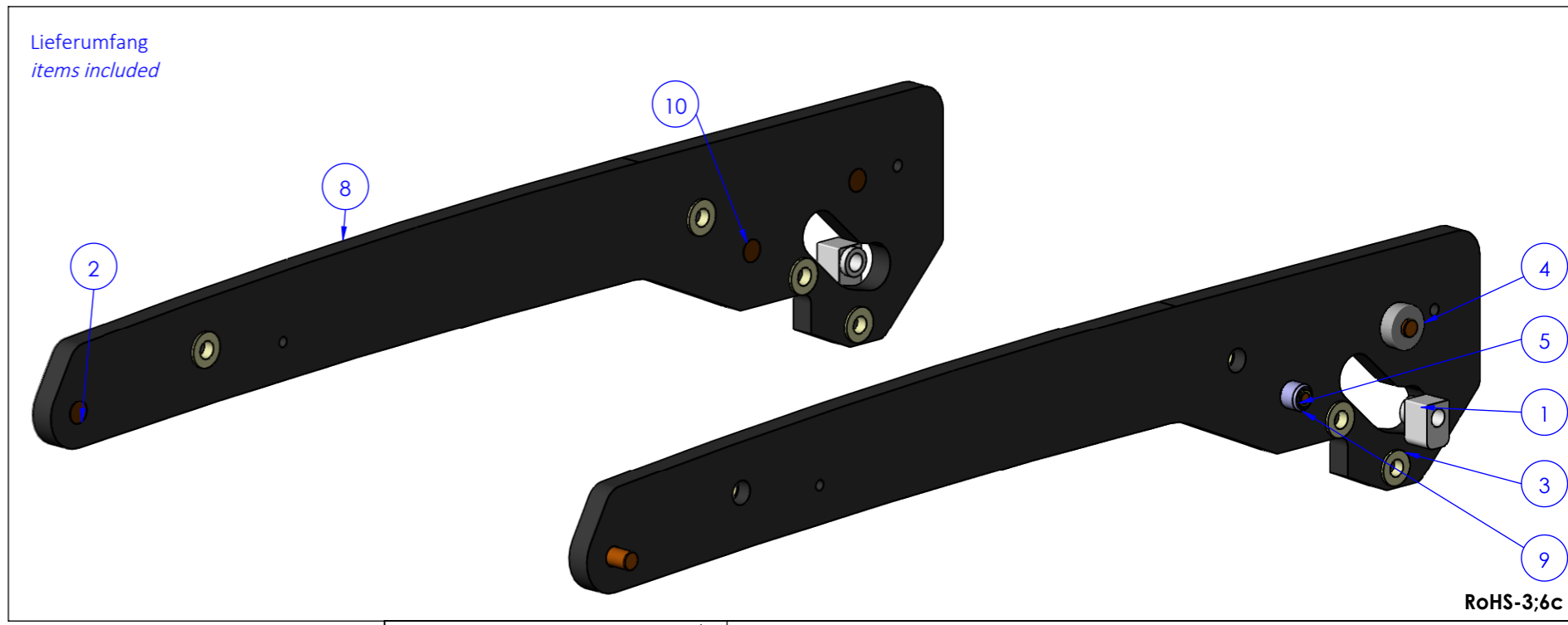

RoHS-3:6c

Maßstab/Scale: 1:5	Benennung/Designation: ETK-KOP-MA2x13/14 Ersatzteilkit replacement kit	Index: 3	Blatt/Sheet 1 von 1
gespeichert/saved: 20.10.2020 16:11:40	Artikel-Nr./PartNo.: 46221		DIN A3
Montageanleitung/instruction sheet			

