

Drive shifting unit

AVE-VA2xxx

Item 21729



GO TO PRODUCT

ingun[®]

Partner for Future Technology

- Compact, robust design
- Quick, easy installation
- 15,7 mNm Anhaltmoment

Application

Die Getriebemotoreinheit wird genutzt als Antrieb für die 2-Stufen Verschiebeplatte in 2-Stufen Vakuum-Prüfadaptern der Serie VA 2xxx-2e.

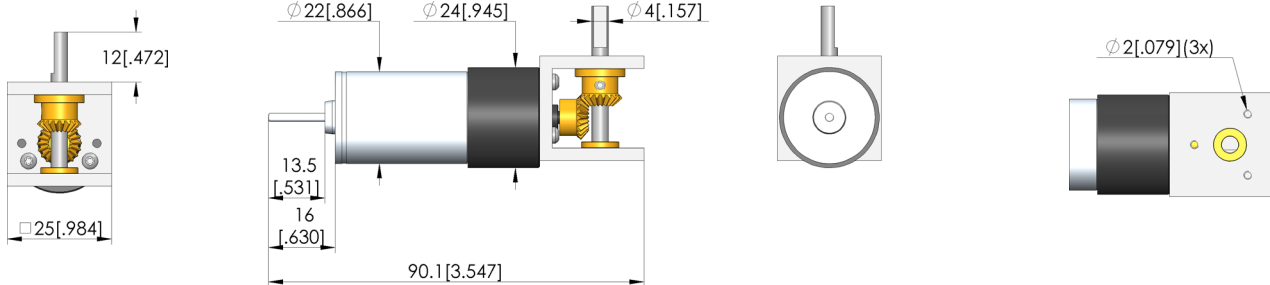
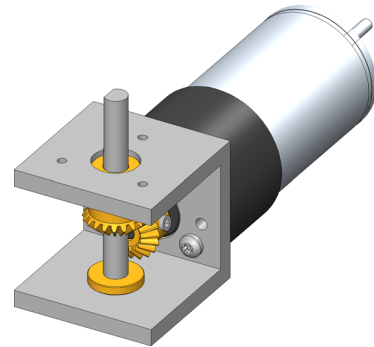

General data

Product group:	Electric accessory
Series:	MOT
Type:	
Version:	
Accessory type:	Customising accessories
Width:	25 mm [.984 in]
Height:	25 mm [.984 in]
Weight:	0.09 kg [.198 lbs]
Min. temperature:	10 °C [50 °F]
Max. temperature:	60 °C [140 °F]
RoHS-compliant:	Yes

Compatible with

Vacuum test fixtures (VA): VA 2xxx-2e

Technical data

Connection:	
Installation:	Thread M2
Max. voltage:	12 VDC
Length:	90.1 mm [3.54 in]
Outer dimensionS (WxDxH):	25 x 90.1 x 25 mm [.984 x 3.54 x .984 in]

INGUN Prüfmittelbau GmbH

Max-Stromeyer-Straße 162
78467, Constance, Germany
Phone +49 7531 8105-0
Customer hotline +49 7531 8105-888
Fax +49 7531 8105-65
info@ingun.com



Prices and delivery times on request.
Technical changes reserved. 04/26_GB