

# Battery contacting multi-head BCM-667-0000 C01-00-00

产品 BCM-667-0003



直接访问产品

ingun®

Partner for Future Technology

- 可靠触探电芯
- 采用模块化设计, 可通过成熟可靠的 INGUN 标准产品扩展电流传输
- 可通过中心感应触点监测电压
- 可选扩展通过 TKS-667 接触面测量温度
- 可通过螺栓轻松灵活地安装在板或汇流排上



## 使用

BCM-Series is specially developed for the flexible scalability of high-current contacting. The modular design makes it possible to adapt the product characteristics to the application, and therefore always provide the right product for a high variable range of DUTs, as is the case with the contacting of battery cells.

## 结构

HCM-Products each consist of a base body and several high-current test probes which create a parallel circuit. The functionality can be additionally extended using a centrally positioned sense contact probe or temperature measurement probe with integrated sense tap.

## 安装

BCM Products can be installed in a corresponding hole on a probe plate using lock nuts or installed directly in a busbar via a corresponding threaded hole. If a BCM Product is installed in a non-conductive plate, for example, the current connection can be made at the threaded bolt via a cable lug. The optional sense contact probe, to be connected to the soldering recess provided, and the temperature sensor are dissipated centrally.

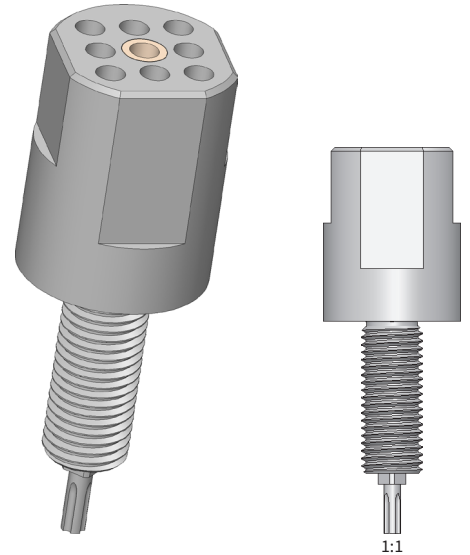

## 提示:

The base bodies are designed for either five or eight current-transmitting test probes from the BCP-120, BCP-113 and BCP-667 series with various tip styles, which can be freely configured in terms of both quantity and layout. By combining the modular high-current multi-head solution with BCP-667 probes, which were specifically developed for contacting battery cells with oxidised contact surfaces, it is possible to greatly reduce the power losses that occur during cell production.

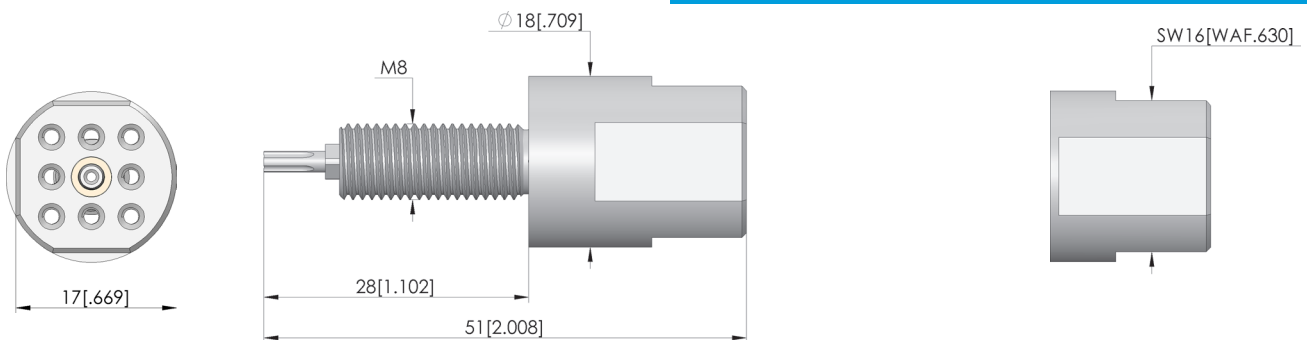

# Battery contacting multi-head BCM-667-0000 C01-00-00

产品 BCM-667-0003



直接訪問產品

ingun®

Partner for Future Technology

## 一般数据

Screw-in torque max.:	100 cNm
产品组:	标准大电流探针 (旋接式)
子产品组:	标准大电流探针 (旋接式)
结构系列:	
Application rec.:	
栅格:	19 mm
电磁:	是
安装类型:	可旋入
快速更换系统:	否
探针上的连接类型:	螺纹接口
安装高度, 可调:	否
防扭转:	是
旋入扭矩:	100 cNm
最小温度:	-100 °C
最大温度:	200 °C
RoHS 符合性:	是

## 针头形状数据

针头形状 表面: A 金

## 电气数据

电阻 (Ri) 典型值, 活塞上的连接: 1 mOhm

## 机械数据

总长: 51 mm  
针管直径: 18 mm

## INGUN Prüfmittelbau GmbH

Max-Stromeyer-Straße 162  
78467 Konstanz, 德国  
中央办公室: +49 7531 8105-0  
客户热线: +49 7531 8105-888  
传真 +49 7531 8105-65  
info@ingun.com



根據要求提供價格和交貨時間。  
保留技術更改。06/26\_CN

关于该主题的更多信息  
大电流探针



大电流探针