

Interface block

SB-P-VA-001-PG16

Item 109725



GO TO PRODUCT

ingun[®]

Partner for Future Technology

- Equipped with PG16 quick-release fitting
- Suitable for use in all test fixtures with Pylon interface
- Reliable transfer of vacuum within the scope of the specification

Application

Interface blocks (SB) are used to reliably transmit signals between test device and test system in internal and external Pylon interfaces. Vacuum blocks are suitable for the reliable transmission of vacuum within the scope of its specification. They are primarily used with vacuum test fixtures with a Pylon interface.

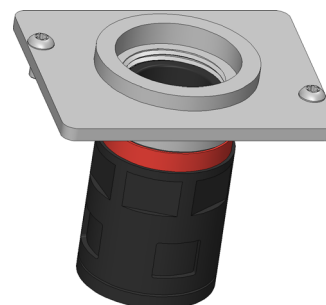

Delivery

Delivery includes PG16 quick-release fitting, including installation accessories.

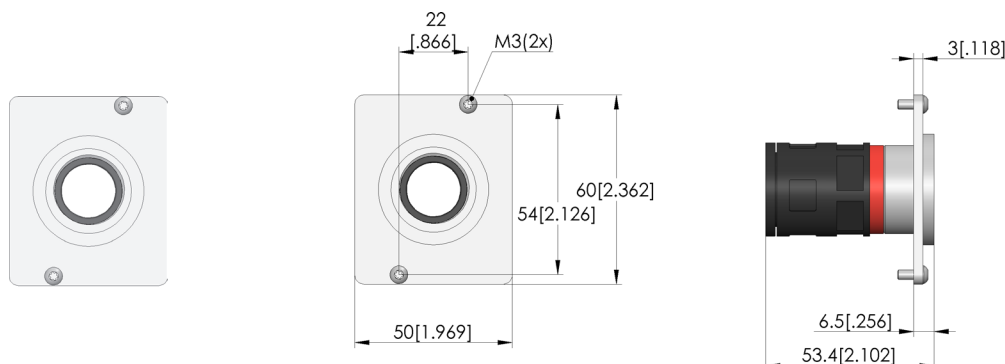

General data

Product group:
Series:
Type:
Version:
Accessory type:
Component assembly:
Weight:
Min. temperature:
Max. temperature:
RoHS-compliant:

Interface blocks (SB)
SB-VA

Device under test (DUT) side
Customising accessories
RQG-P (PG 16)
0.029 kg [0.063 lbs]
10 °C [50 °F]
60 °C [140 °F]
Yes

Compatible with

Compatible mating part 1:
MA exchangeable kits (ATS MA):

SB-T-VA-001-PG16-ALU
ATS MAxx

Technical data

Working distance:
Connection:
Sealing:
Number of poles:

15,1 +/- 0,5 mm
Vacuum tube PG16
Elastosil @
1 (fixed position)

INGUN Prüfmittelbau GmbH

Max-Stromeyer-Straße 162
78467, Constance, Germany
Phone +49 7531 8105-0
Customer hotline +49 7531 8105-888
Fax +49 7531 8105-65
info@ingun.com



Prices and delivery times on request.
Technical changes reserved. 03/26_GB